



Oxyzone International Pty. Ltd.

Model T4400 Ozone Generator



Instruction and Maintenance Manual

V1.0 – Nov 2020

Contents:

1. 4400 Specification
2. Unpacking and installation instructions
3. Maintenance and repair instructions
4. T4400 Block diagram
5. T4400 DIN connector wiring

1. Specification and operation of the Oxyzone T4400 ozone generators

Description:

The T4400 is the 4 cell version of the T4600 and is built to be the same dependable product as the larger systems. With its stainless steel construction it is ideal for use in the food industry where it can provide sanitising ozone treatment for automatic equipment or processes.

Offering an ozone output of 20 gm/hr using oxygen it is a very versatile product with the ability to provide large savings in a food processing environment.

External control:

The T4400 is provided with an XLR 3 pin connector for control by an external ORP or dissolved ozone monitor.

Models available:

- T4400 - 20 gram/hr, 4 cell ozone generator with input for ORP control.
- T4400V – Fitted with variable output power supplies



At Oxyzone we have the product and the flexibility to meet your needs.

T4400 specification

Cabinet size	Width	Height	Depth
All models	450mm	600mm	210mm
Weight	30kg		
Cabinet material	Grade 304 Stainless Steel		
Ozone output	20 gm/hr at 20C using PSA oxygen		
Ozone producing cells	4 individual air cooled cells		
Power supplies	4 Individual high voltage; high frequency power supplies with overload protection		
Power requirement	240 vac, 50 Hz, 500W nominal		

Models available

T4200	4 cell, 20gm/hr Corona Discharge ozone generator
T4200V	4 cell CD ozone generator with variable output

Controls and indicators

Start / Stop	Illuminated mains switch
Circuit protection	3A thermal circuit breaker
Safety	Low voltage door interlock switch
Indicators	4 LED indicators showing that the power supplies are operating correctly
External control	3 pin XLR connector for external controller
Flowmeter	Indicates the flow level of the oxygen or air feed: 0 to 10LPM for oxygen

2. Unpacking and installation of the Oxyzone T4400, T4400V ozone generator

T4400 Item list

With your T4400, T4400V ozone generator you will receive the following:

- 1) P/N 40012 -T4400 mounting strap x 2
- 2) P/N 41034 - M8 x 12 Csk screws x 4
- 3) 41806 Door key, 3mm double bit x 1
- 4) 40613 Teflon thick wall 3/8" tubing, 3m (4400, oxygen feed)
- 5) 42034 XLR 3 pin male in-line connector with pins 1 and 2 linked

Mounting the unit

The unit is not sealed sufficiently to allow mounting in an environment that is hosed down with water or exposed to rain.

When mounting on a wall ensure a space of 200-300mm at each side to allow clear cooling airflow. Clear access to the RH side is helpful for servicing the wiring and electronics.

Allow a space of about 200mm below the unit to facilitate tightening of fittings.

No access is required to the top of the unit.

Stand the ozone generator on its head and fit the 2 mounting straps using the M8 countersunk screws.

Fasten the unit securely to the wall using the holes in the mounting straps; 1/4" or 6mm diameter bolts are adequate.

Connecting the unit

Open the door and check that no apparent damage has occurred in transit. Check by hand that the unions at the base of the cells are tight.

When viewed from the front of the unit, the rear 1/4" BSP connector is the air or oxygen inlet. This is in the form of a 1/4" BSP T piece with a hosetail fitting on one side and a plug on the other. They can be fitted either side of the T; they may be only finger tight when supplied.

Connect either a source of oxygen, clean filtered air or the small filter to this outlet.

The front 3/8" BSP connector is the ozone outlet and is also fitted with a T piece, hosetail/compression fitting and plug.

This outlet may be fed to an injector using the silicon tube or Teflon tube provided. With oxygen feed the ozone concentration is far higher and Teflon tube is supplied. With air feed the silicon tube is adequate and easier to work with.

When running on air feed, the ozone generator will produce minute quantities of nitric acid as a result of exposing humid air containing nitrogen to a high voltage field. This will be drawn in with the ozone and mixed into the water with negligible effect. With oxygen feed nitrogen is not present and nitric acid is not produced.

Setting up the unit

The 4400 will normally be used to produce ozonated water. If using the product to provide gaseous ozone only then please request the special instructions that are required for that application.

With the 4400 switched off, connect the ozone outlet to the injector. If using oxygen feed then disconnect the oxygen generator or bottle as flow from this will affect the initial adjustment.

Using the back pressure valve and bypass valve adjust the air oxygen flow to give 5LPM ie a slight positive pressure from the supply.

The 4400 can be controlled by an external ORP or other controller. Depending on your delivery instructions, the 4400 will be configured with a link fitted to the PCB or a 2 pin plug with wiring to the 3 pin XLR connector. The XLR connector and harness are installed in the 4400 but not connected to allow you to change in the future.

The 4400 is now ready to be switched on. If using oxygen the ozone gas from the outlet will be at a very high concentration (around 30,000ppm) and is dangerous if inhaled. Ensure that the ozone outlet is connected to the injector and that there is suction present.

Open the door, connect the 3 pin mains plug and switch the 4400 on. With the door open it will not run but the mains switch will be illuminated.

Close the door and the cooling fans will run. If the link is fitted to the control PCB then the High Voltage (HV) power supplies will both operate and the indicator LED's will be illuminated.

If the XLR wiring is connected to the control board then with the XLR shorting plug removed neither of the HV power supplies will operate.

Connect the XLR shorting plug to the 3 pin socket and the system will start to produce ozone. All the LED indicators should be lit indicating that the power supplies are functioning.

The T4400 is normally wired to allow the ozone generated by both cells to only commence when an external device or connector causes pins 1 and 2 of the XLR connector to be shorted. The pre-wired shorting connector is provided to allow that to happen without an external device.

The external device can be an ozone level monitor or an ozone safety monitor. It can simply be a relay contact operated by someone switching on the lights. It must not be connected to a voltage source as it only uses 12VDC supplied by the internal power supply.

We can change this configuration, before delivery, to provide both cells operated by the external device or one cell on permanently and one cell operated by the external device. A wiring diagram is provided to allow the customer to change this himself if desired.

3. Maintenance and repair of the Oxyzone T4400 ozone generator

Periodic maintenance

The only maintenance is the periodic cleaning of the cells. This will be dependent on the cleanliness of the air supply. Make the first clean at 2 months for air feed or 4 months for oxygen and adjust the time as required.

You will require a small bath of methylated spirits, a stainless steel scouring pad and a bottle brush to carry out the cleaning plus it's advisable to use plastic gloves to protect your hands.

Firstly, disconnect all power to the unit.

Open the outer door and the power supply door to allow access to the cells.

Note the position of the pipework to facilitate reassembly.

Remove the high voltage connections at the top of the cells.

Remove the silicon pipe from the ozone cells, if it is tight then cut it off instead. Do not force it as the Teflon cap cannot withstand high mechanical stress.

Using pipe grips; loosen the union at the base of the cell and remove the complete assembly from the cabinet. Repeat for the second cell etc.

See separate "Cell Maintenance" Instruction sheet.

Replace the Viton O rings in the union at the base of the cell prior to fitting.

Reconnect the silicon tube and the high voltage leads. If they are loose then look down the end and give a small squeeze across the metal connector tube with pliers.

Wipe clean the inside of the cabinet before final assembly and running.

Repair of the 4400

General

If fans don't operate then the circuit breaker has probably tripped. Before simply resetting it, remove the side panel and check that the machine has not been subject to water ingress or insect infestation.

If the fans operate but no power supply indicators light then insert the XLR shorting plug. If indicators then light the problem is external to the machine.

If the indicators fail to light then the fault is probably in the control PCB or the 12VDC power supply.

Use the schematic diagram to diagnose the cause of the problem.

HV Power supply replacement

If a power supply LED on the control board is not lit then the cause will most likely be a HV power supply or cell failure. The power supplies are fitted with over current protection that causes them to shut down if a cell goes short circuit for any reason. The over current protection circuit is reset when mains power is removed and then reapplied. Power supplies are numbered left to right, i.e. the right hand power supply is number 2.

Remove the securing screws from the power supply door, open the door and check that the 3 pin IEC mains connector on the power supply has not been dislodged in transit. Close the door and switch on to confirm.

Remove the HT lead from the failing power supply and place it where it will not short out to the frame. Close the door and switch on. If the power supply LED fails to light then the power supply is probably faulty and should be replaced. If the power supply LED operates then the cell is probably faulty and should be dismantled and checked. Look for a small fracture in the quartz or burn marks at the lower end.

If water ingress has occurred and the power applied at that time then a short can develop which will quickly burn a track through the Teflon end of the quartz cell. The quartz cell is not repairable and not expensive.

To replace a power supply, remove the mains connector and the 2 pin signal connector. Loosen the 4 hex screws and remove the power supply. Refit in the reverse sequence.

OZ-4400 BLOCK DIAGRAM

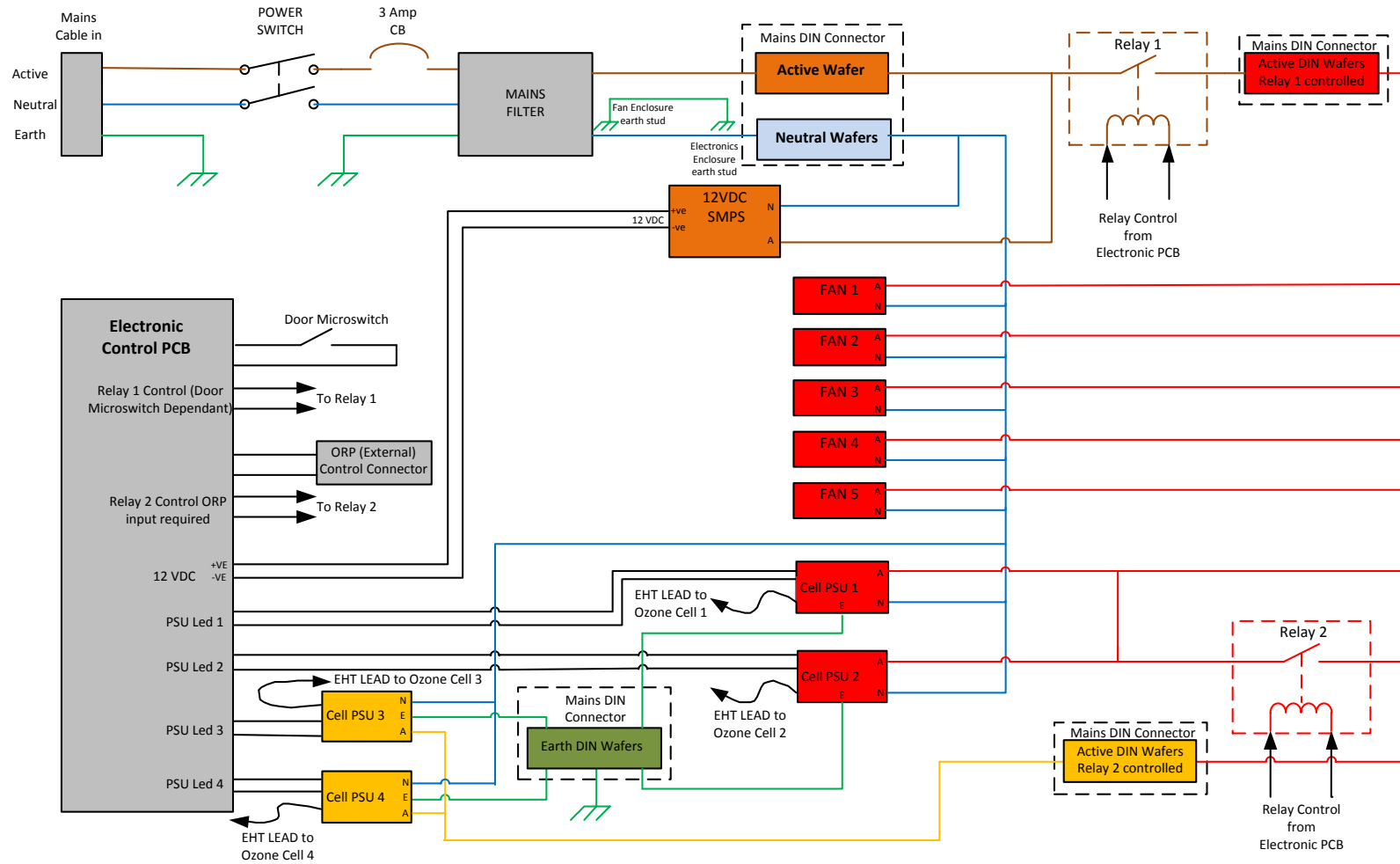

T4400 Mains Connector Wiring

